

Title		
Main Board Top Chart		
Size	Document Number	Rev
A3	<Doc>	<RevCo
Date:	Tuesday, December 17, 2019	Sheet 1 of 10

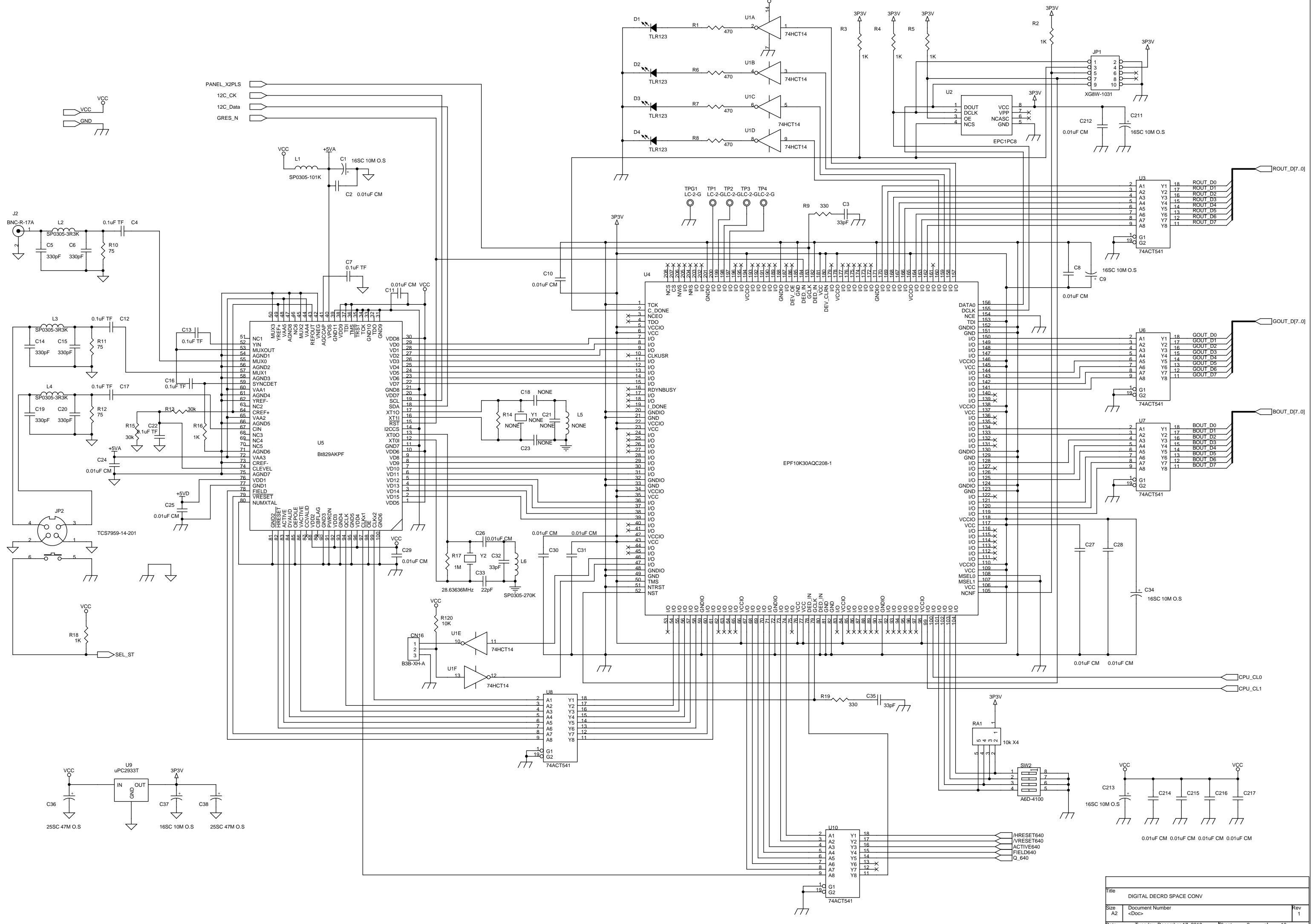

Title	DIGITAL DECRD SPACE CONV		
Size	A2	Document Number	<Doc>
Date:	Tuesday, December 17, 2019	Sheet	2 of 10
Rev	1		

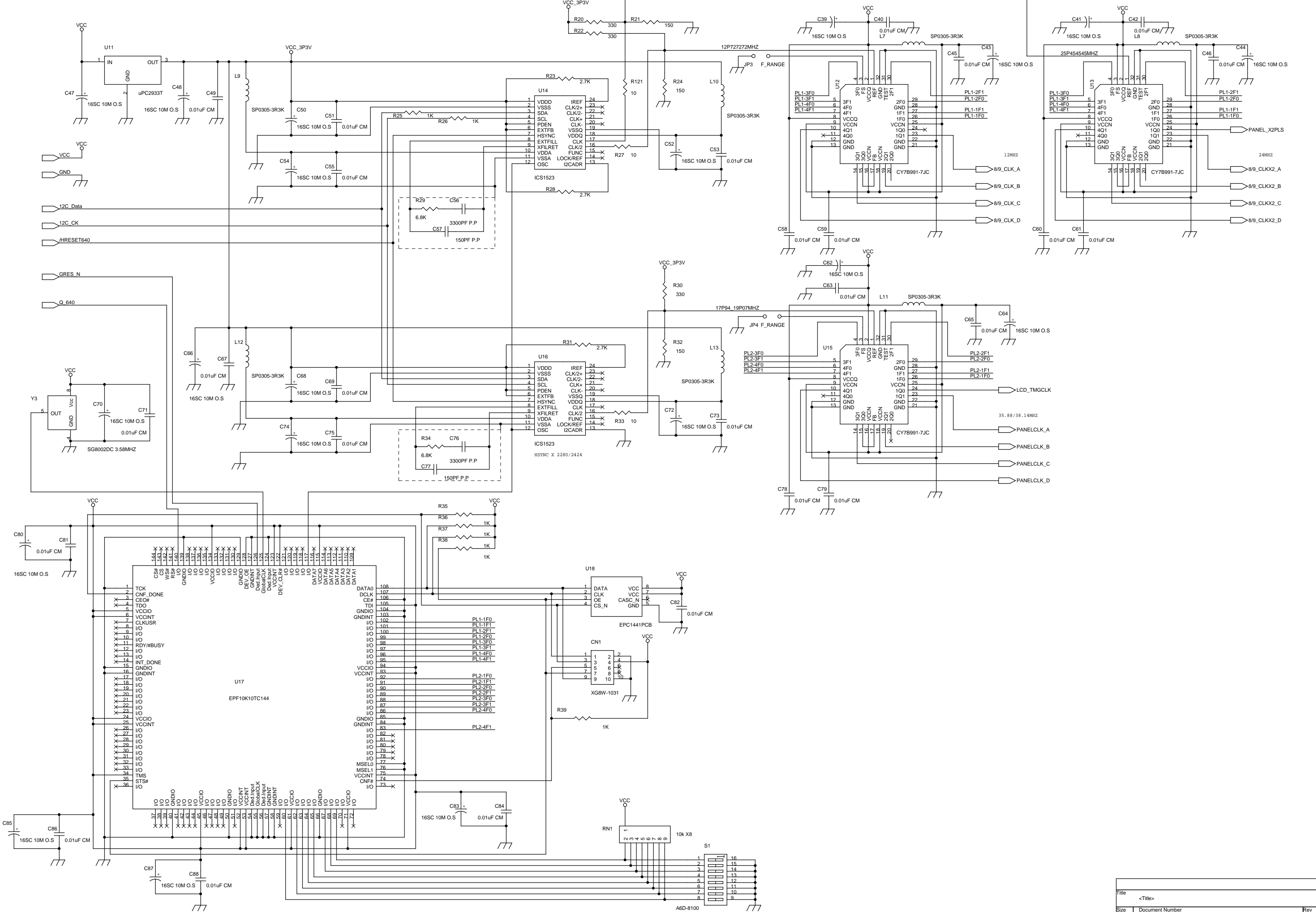

Title	<Title>	Rev	1
Size	A2	Document Number	<Doc>
Date:	Tuesday, December 17, 2019	Sheet	3 of 10

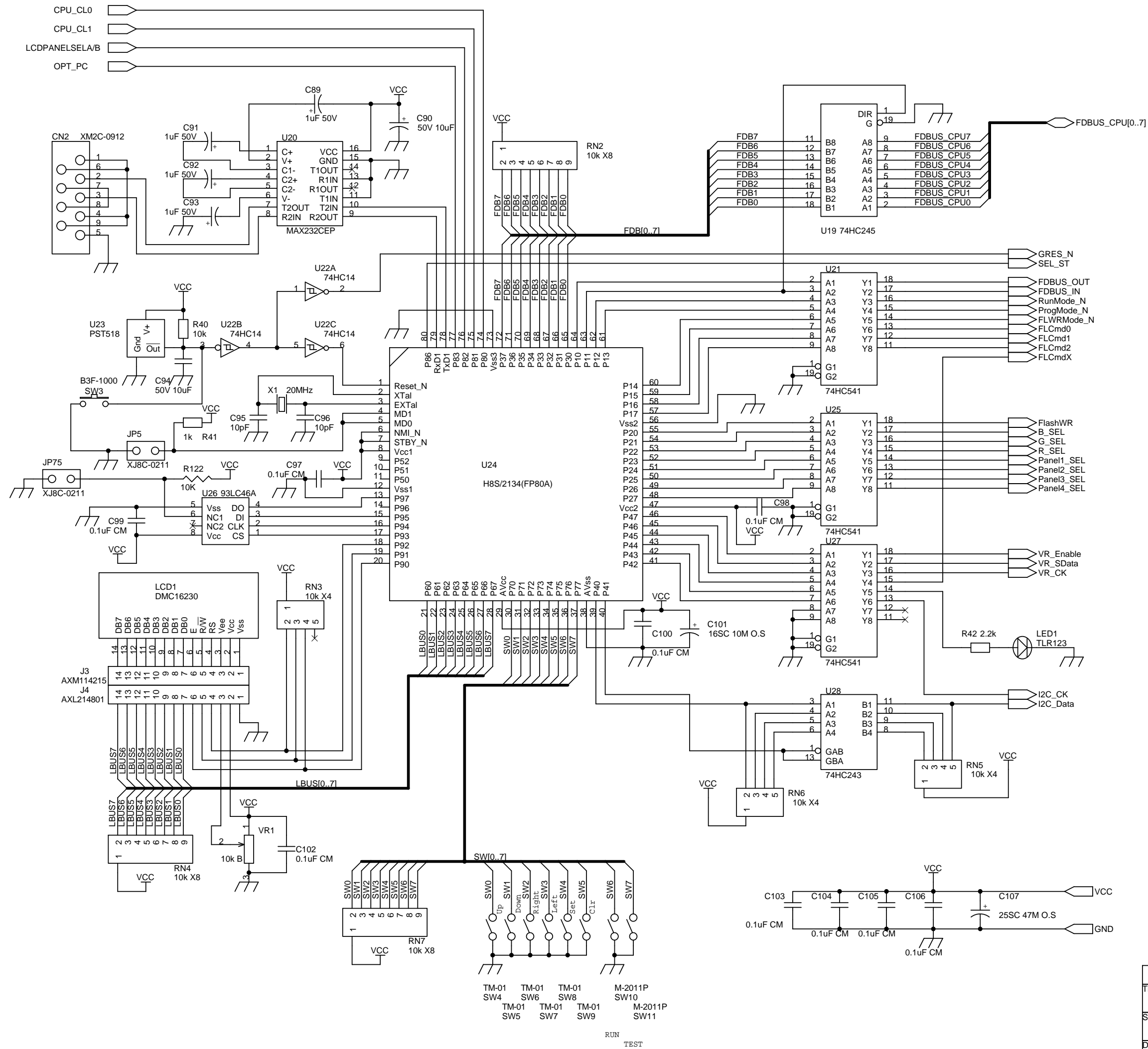

Title		LUT / CPU
Size	Document Number	Rev 1
A3	<Doc>	
Date:	Tuesday, December 17, 2019	Sheet 4 of 10

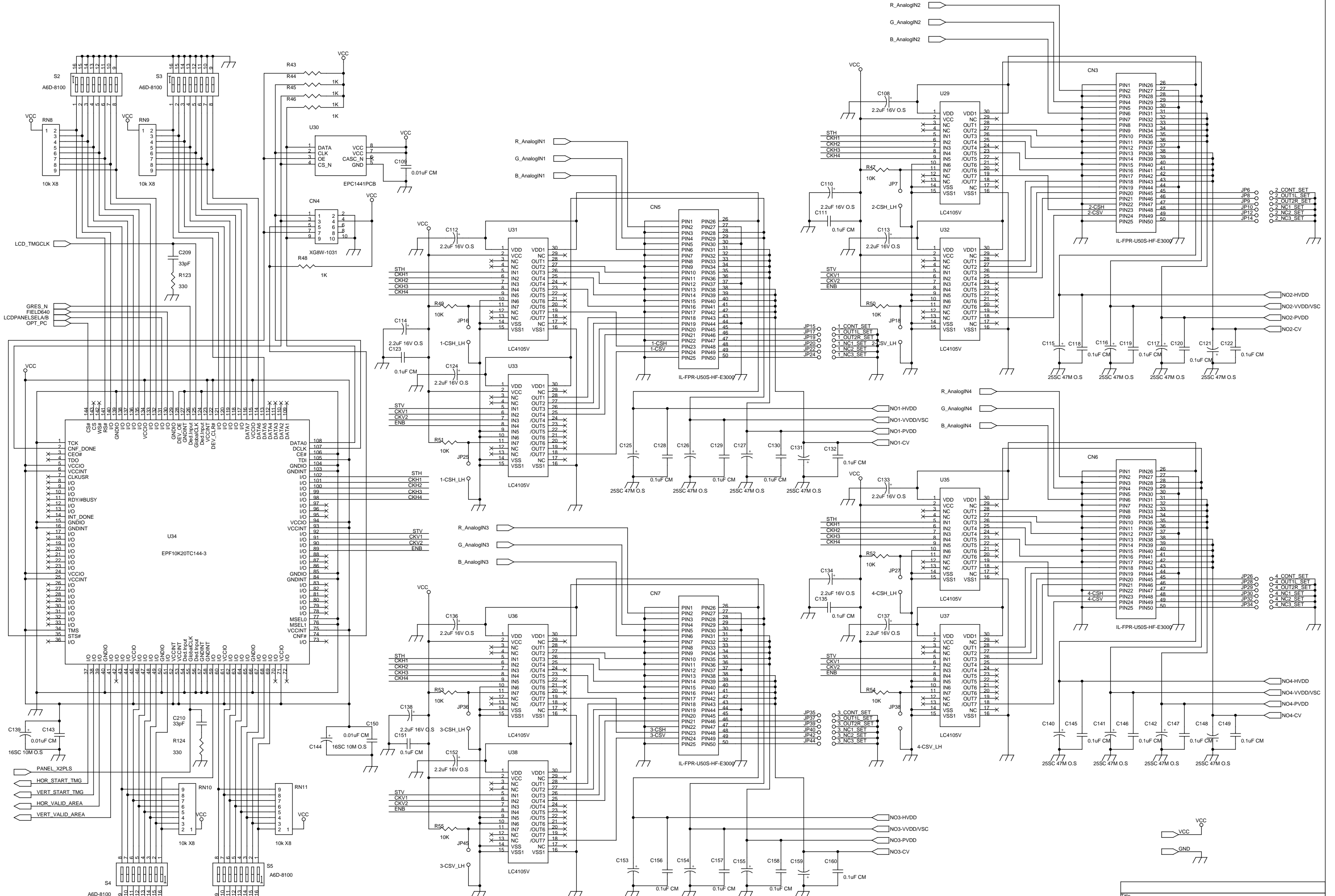

Title	<Title>	Rev	1
Size	A2	Document Number	<Doc>
Date:	Tuesday, December 17, 2019	Sheet	5 of 10

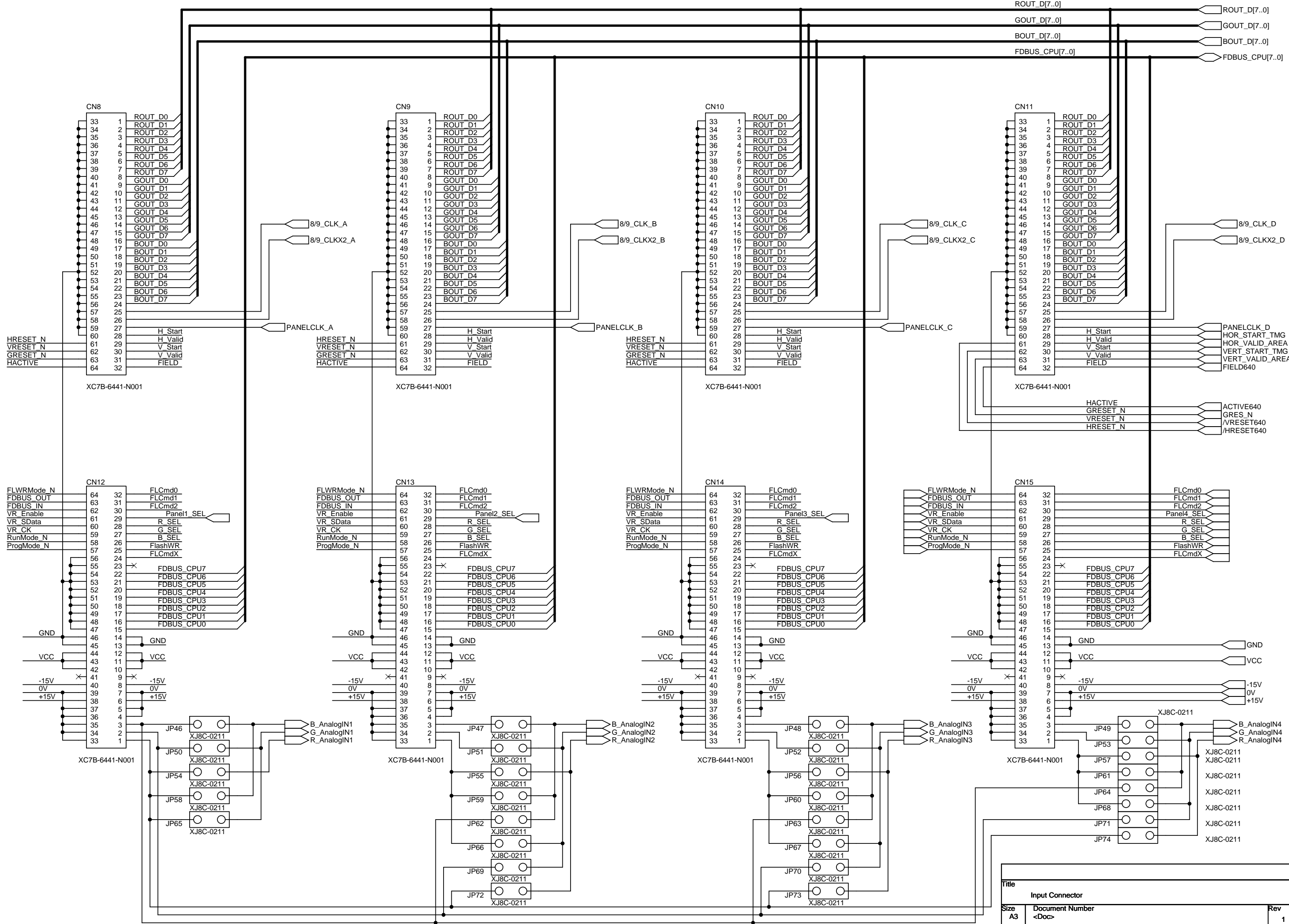

Title		
Input Connector		
Size	Document Number	Rev
A3	<Doc>	1
Date:	Tuesday, December 17, 2019	Sheet 6 of 10

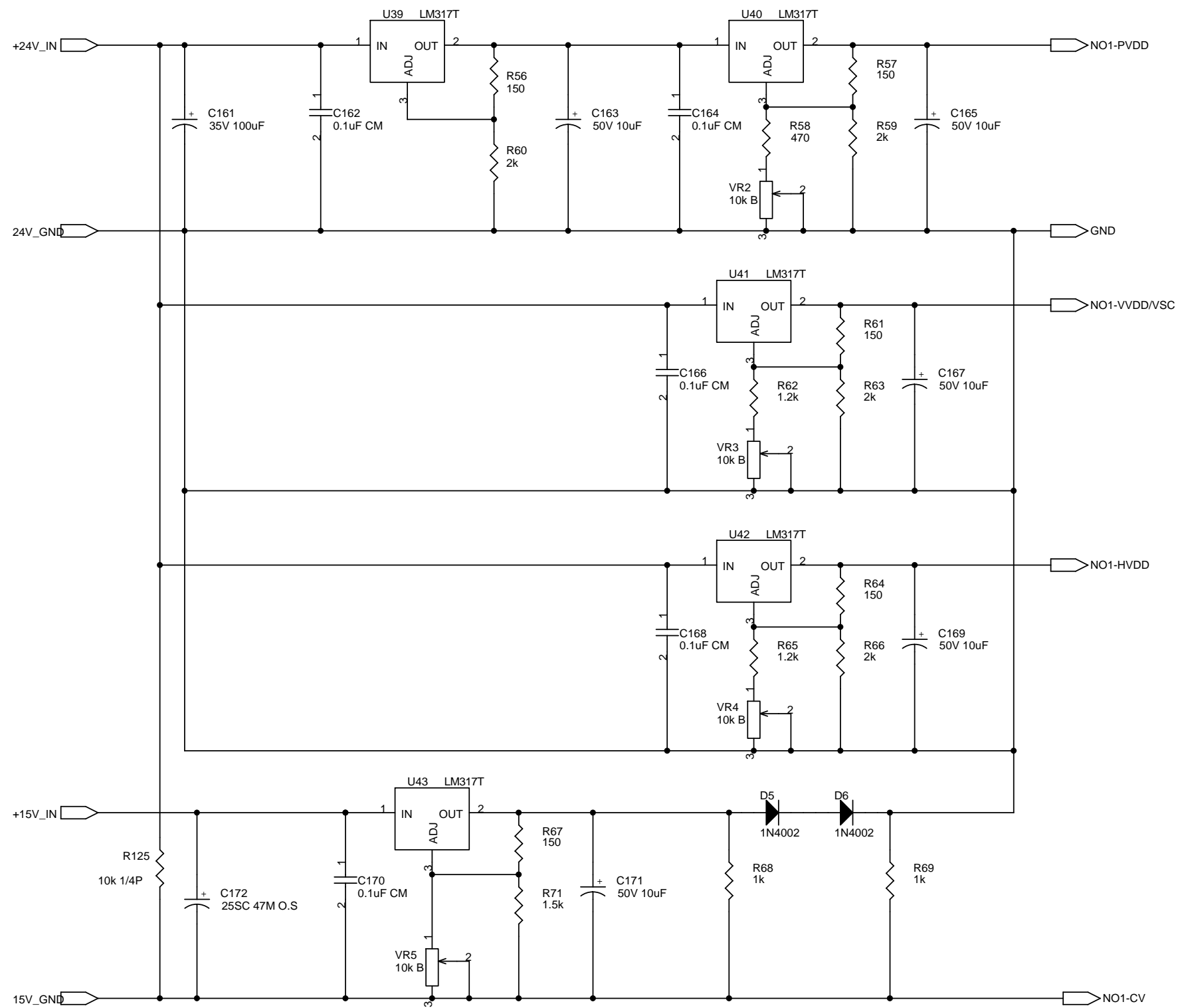

Title		
EL Power		
Size	Document Number	Rev
A3	<Doc>	1
Date:	Tuesday, December 17, 2019	Sheet 7 of 10

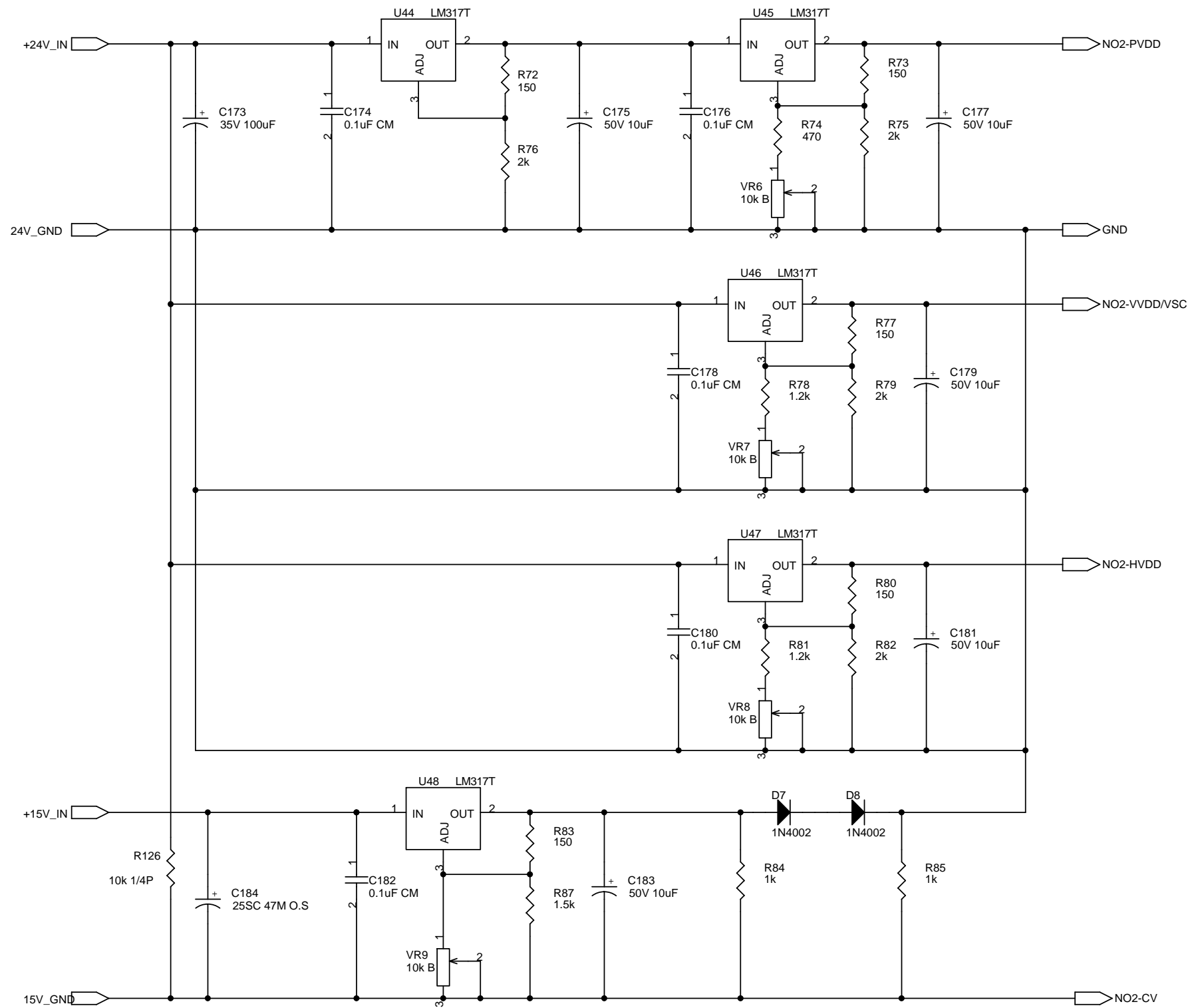

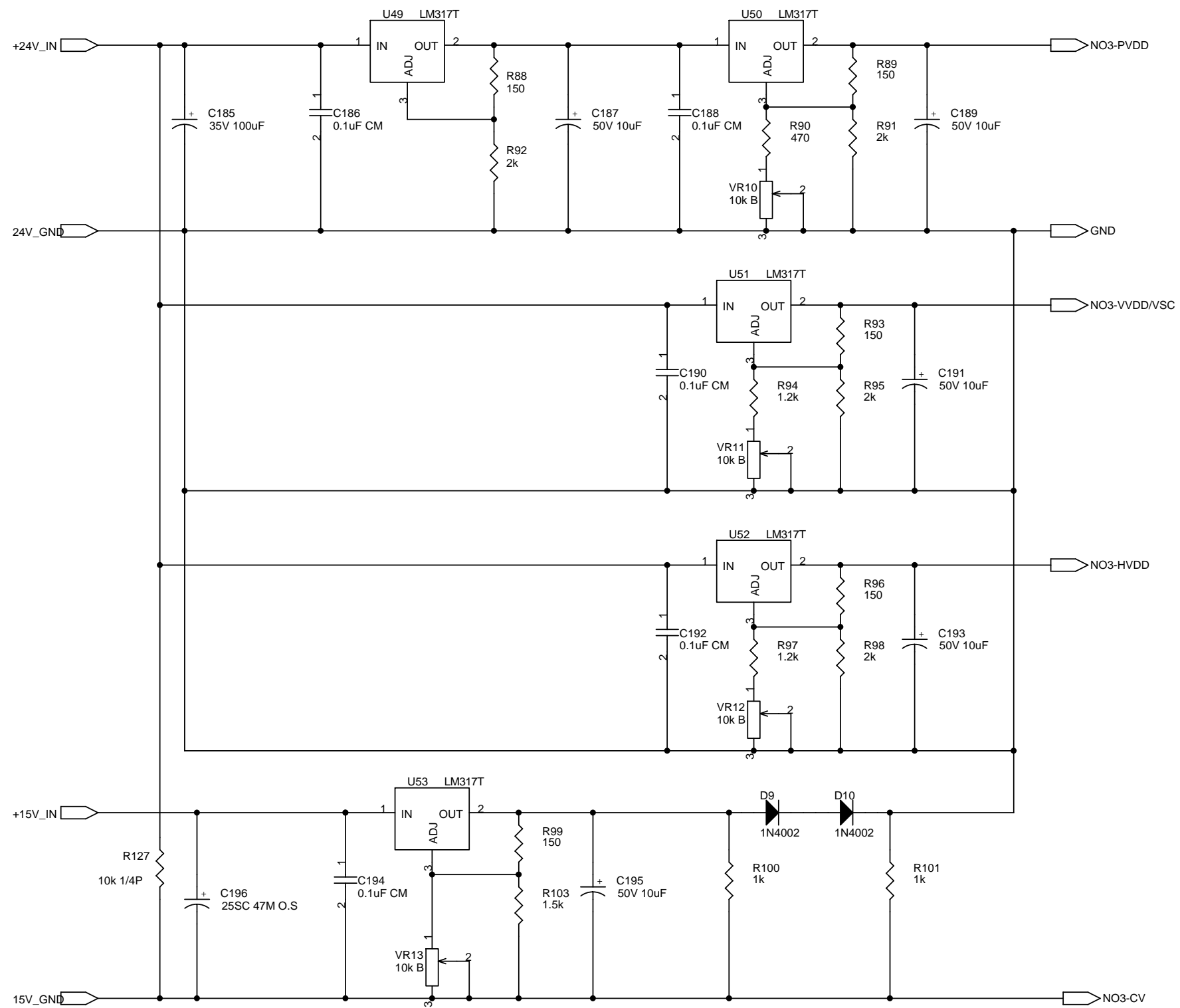

Title		
EL Power		
Size	Document Number	Rev
A3	<Doc>	1
Date:	Tuesday, December 17, 2019	Sheet 9 of 10

